

AKD-125  
AKD-125-FF  
ICE DISPENSER

**KOLD-DRAFT**



CLASSIC

# Installation & Operation Instructions

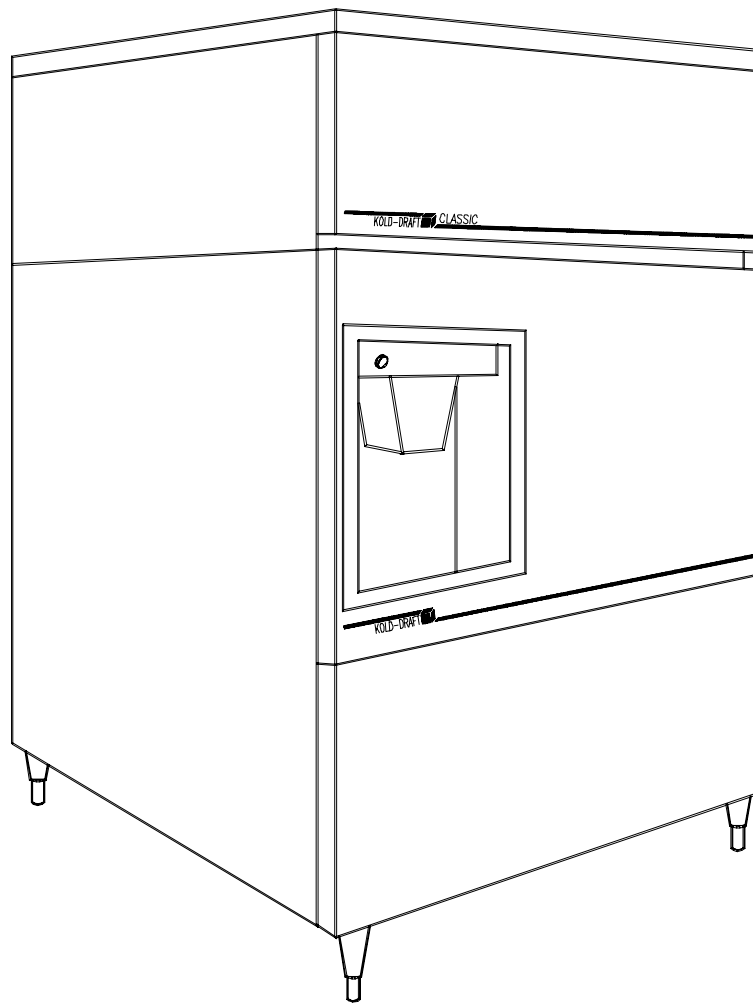

**KOLD-DRAFT**



Ice Machine Products

an Ali Group Company



The Spirit of Excellence

*A Tradition of Excellence In Ice Equipment.*

## Installation and Operation Instructions for Kold-Draft® AKD-125 Ice Dispenser

CHECK FOR FREIGHT DAMAGE BEFORE PROCEEDING: Even though damage to the carton may not have been evident, check for hidden damage and contact freight carrier immediately if necessary to file a claim.

**THIS EQUIPMENT MUST BE INSTALLED IN COMPLIANCE WITH THE APPLICABLE FEDERAL, STATE/PROVINCE AND/OR LOCAL PLUMBING, ELECTRICAL AND HEALTH/SANITATION CODES AND REQUIREMENTS.**

### CAUTION:

- ◆ RISK OF PERSONAL INJURY, PROPERTY DAMAGE, EQUIPMENT FAILURE OR FIRE.
- ◆ Refer all maintenance to qualified personnel.
- ◆ Never operate this equipment with covers, panels or other parts removed or not properly secured.
- ◆ Warn all users to clean up spillage immediately, and report any apparent leakage or unusual sounds to maintenance personnel.
- ◆ Proper installation must include **Kold-Draft®** GT Series Ice Cuber mounted above Dispenser

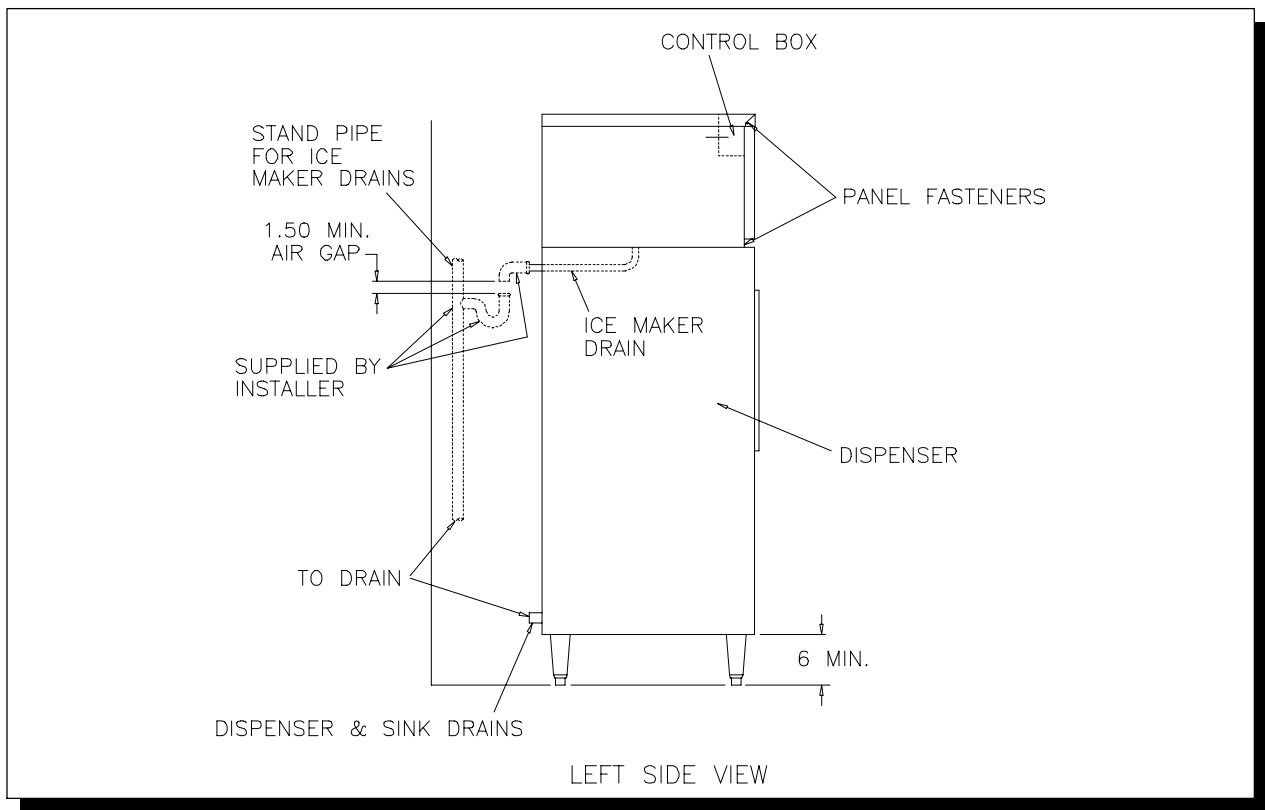

## INSTALLATION

**NOTE:** Refer to ice cuber instructions before proceeding.

1. CAREFULLY remove the carton from the dispenser.
2. If the dispenser is to be mounted on the 6" legs provided, carefully place the unit on its back and install the legs in the threaded mounting holes.
3. Position the dispenser maintaining the minimum clearances specified in the cuber instructions.
4. Level the dispenser by adjusting the legs, or by shimming if the unit is to be sealed to the floor. If gaps due to shims are greater than 1/8 inch, install a cove molding around the dispenser bottom. Seal the dispenser or molding to the floor with NSF Certified RTV sealant (Dow-Corning RTV 732 or equal).
5. Electrical and drain locations are shown below. All dimensions are in inches.
6. Install gasketing on top of dispenser. (See Illustration "A")

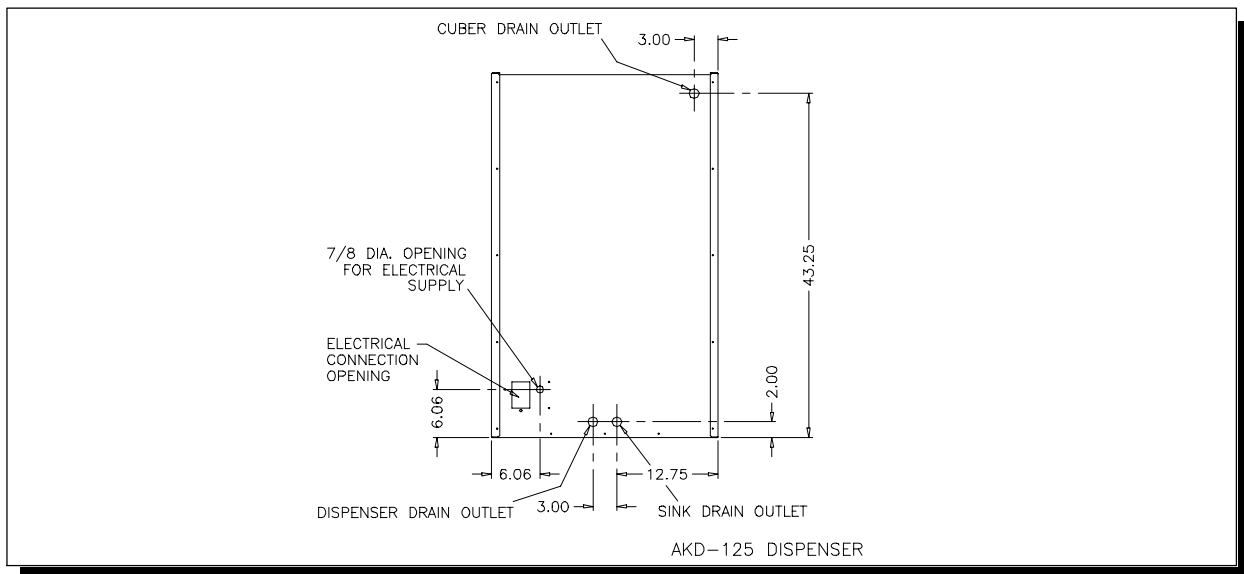

7. Remove the cuber cabinet panels, lift and position cuber on top of gasketed

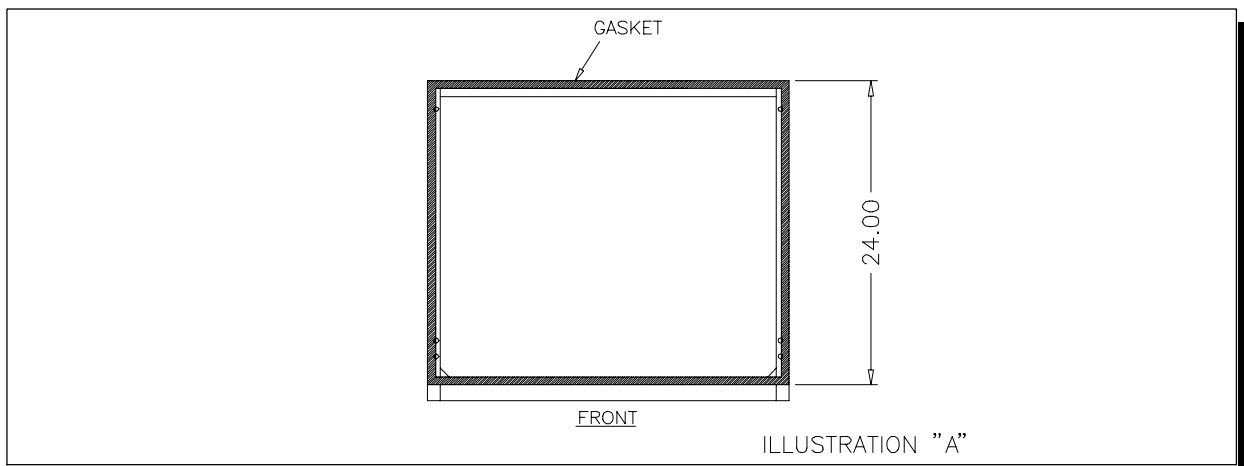

dispenser and align mounting holes. Install cap screws and lockwashers.  
**CAUTION:** support cuber until all fasteners are secured.

8. If the GT cuber that you are mounting on the AKD does not have the hole in the drain pan support, you must do the following:
  - A) Drill out the pop rivet, on the drain pan support that is nearest to the right side of the cuber, with a #27 (.144") drill.
  - B) Attach the bracket to the drain pan support with the s.m. screw provided.
  - C) Slide the S.S. tube through the hole in the bracket.
  - D) Run the bin thermostat cap tube along the right side of the cabinet, then into the S.S. tube. Allow the tip of the cap tube to protrude slightly past the end of the

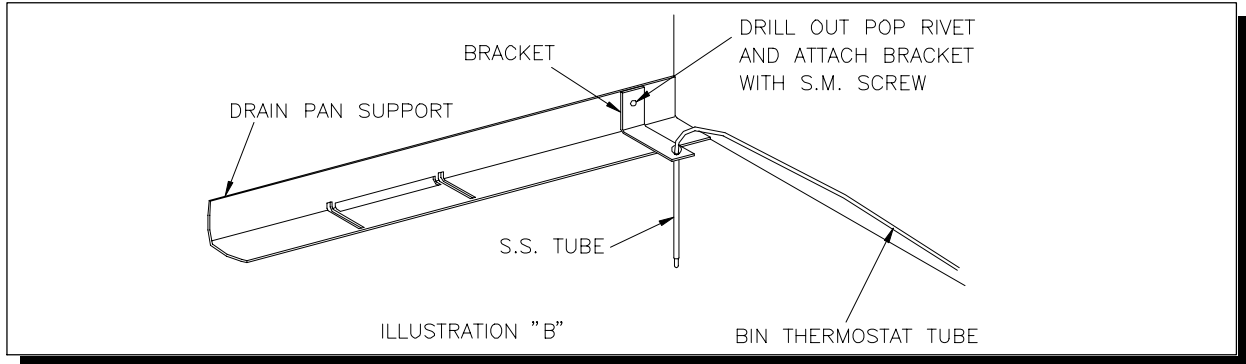

S.S. tube (See Illustration "B").

9. If the GT cuber has the hole in the drain pan support, then slide the S.S. tube through the hole in the drain pan support, route the bin thermostat cap tube along the right side of the cabinet and through the S.S. tube (See illustration

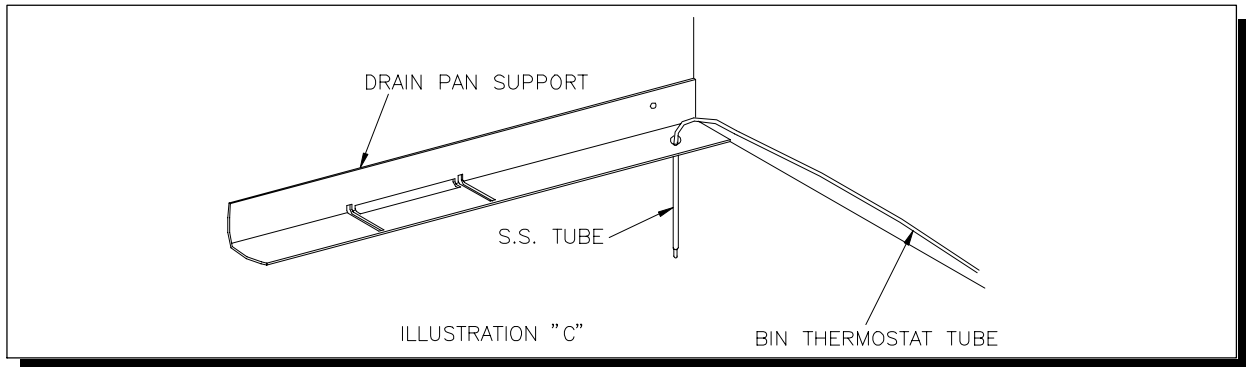

**CAUTION:**

- ◆ Route bin thermostat cap tube away from moving parts.

"C"). The tip of the bin thermostat cap tube should protrude slightly past the end of the S.S. tube.

**INSTALLATION SPECIFICATIONS**

**CAUTION:**

- ◆ Risk of property damage, equipment failure or fire. Comply with all installation specifications for safe operation.

The AKD-125 Ice Dispenser is designed for 115 volt 60 hz. operation. The AKD-125-FF is designed for 230 volt 50 hz. operation.

Refer to equipment name plate data for current value and maximum fuse size. This unit must be provided with a separate, properly protected circuit with no other loads. A fused disconnect installed adjacent to the dispenser is recommended (to be supplied by installer), and may be required by local codes.

This Dispenser is intended for indoor use only with permanent connection to a field electrical supply. This model is intended to be installed only in conjunction with a **Kold-Draft® "GT" Series Ice Cuber.**

**DISPENSER MAINTENANCE**  
*Every 6 Months Minimum*  
**CLEANING**

Always clean the ice maker first, following the ice maker cleaning instructions.

**CAUTION:**

- ◆ Risk of personal injury, equipment damage or contamination of the dispenser bin.
- ◆ Do not use ammonia solutions or strong detergents in cleaning the dispenser.
- ◆ Never use appliance polishes, finish preservatives or cleaners in areas that contact ice.

Remove all ice from the dispenser before starting the cleaning procedure.

1. Remove ice maker top and front panels and drain pan/chute.
2. Loosen the wing nuts on the upper bearing clamp and pull it off to release the top of the auger.
3. Pull the auger up at least 1" on its axis to clear the lower drive mechanism and remove it through the front of the ice maker.
4. Wash the bin interior with a solution of 2 tablespoons of baking soda per quart of clean water (140° F. max.). The dispenser bin can be accessed through the front of the ice maker. Use a long handled brush to reach the bottom of the bin if needed.
5. Wash the sink interior with the baking soda solution and wipe dry with a clean cloth.  
**NOTE:** The spout and spout closure should be removed for thorough cleaning in the solution container and then replaced.
6. Rinse with clean tap water.
7. Replace the auger, making sure that it is fully engaged with the lower drive mechanism. Install the upper bearing clamp and tighten the wing nuts.
8. Sanitize all ice contact surfaces including the ice spout and spout closure with a solution of 1 teaspoon 5-1/4% sodium hypochlorite (chlorine bleach) per quart of clean tap water (minimum 100 PPM free chlorine). A spray bottle will facilitate this process. Pour the unused sanitizing solution over the auger and down the storage area drain.
9. Exterior surfaces may be cleaned by standard methods suitable to the stainless steel finish.
10. Replace the ice maker front and top panels before reconnecting the power supply.

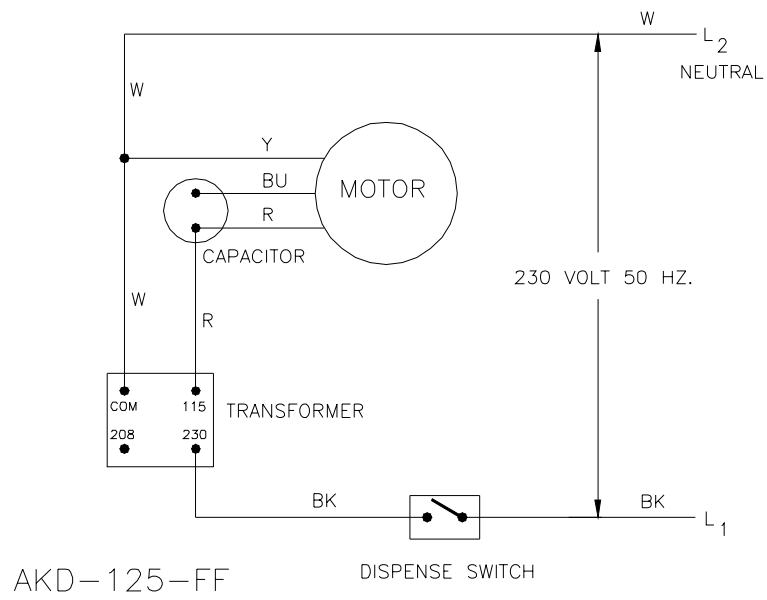
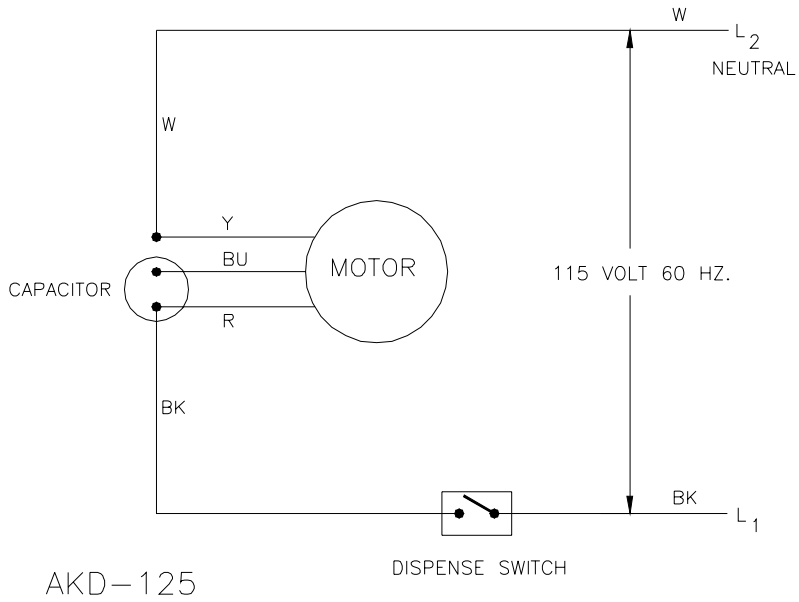

AKD-125 WIRING DIAGRAM  
508 1044 01

**KOLD-DRAFT**

101 Corporate Woods Parkway  
Vernon Hills, IL 60061

USA

847-215-4500

800-726-8762

FAX: 847-541-1759

[www.kold-draft.com](http://www.kold-draft.com)

**KOLD-DRAFT**

an Ali Group Company



The Spirit of Excellence